

► Our technology. Your success.

Pumps • Valves • Service



## **BOA-Compact** – Maintenance-free Soft-seated Globe Valve



### **Applications:**

- Hot water heating systems
- Air-conditioning systems

The limits given in the technical codes must be complied with. Please contact us for details.

### **More information:**

[www.ksb.com/products](http://www.ksb.com/products)

# BOA-Compact – Maintenance-free Soft-seated Globe Valve

- 1 Little pressure loss**  
due to hydraulically favourable flow passage
- 2 One model for shut-off and throttling**  
due to EPDM-encapsulated throttling plug with linear characteristic
- 3 Zero leakage and zero maintenance for life**  
due to lubricated-for-life EPDM profile ring and single-piece body
- 4 Easy insulation**  
due to simple body design and anti-condensation feature (insulating cap)
- 5 Space-saving, low-weight design**  
of body with face-to-face length to EN 558/14
- 6 Fully equipped at no extra price**  
with internal travel stop, position indicator and locking device

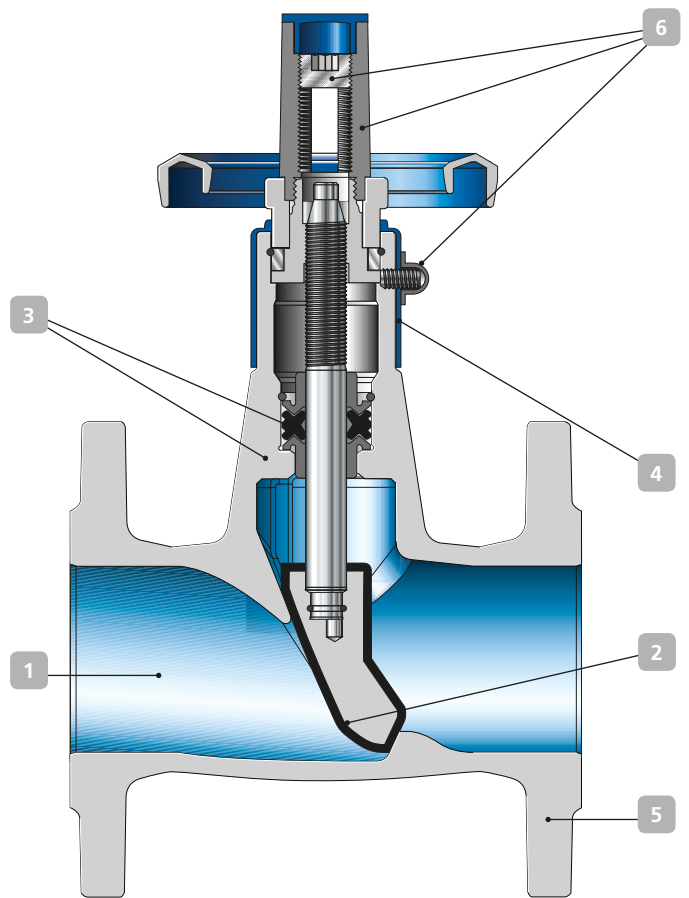

## Related type series



**BOA-CVE Compact**  
Control valve with electric actuator



**BOA-SuperCompact**  
Soft-seated globe valve with face-to-face length to EN 558/94



**BOA-Compact EKB**  
Drinking water approved model with electrostatic plastic coating (EKB)

## Variants

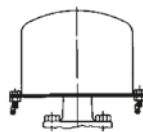

Lead-sealable cap (assembly set)

## Technical data

Material	EN-GJL 250
Nominal sizes	DN 15 to DN 200
Nominal pressure	PN 6 or 16
Permissible operating temperature	-10 to +120°C
Permissible operating pressure	16 bar



**KSB Aktiengesellschaft**  
Johann-Klein-Straße 9  
67227 Frankenthal (Germany)  
www.ksb.com